

EPURATEUR SPN 7 à 20

Pièces de rechange

PLAN n° C 7587

SPARE PARTS

ERSATZTEILE

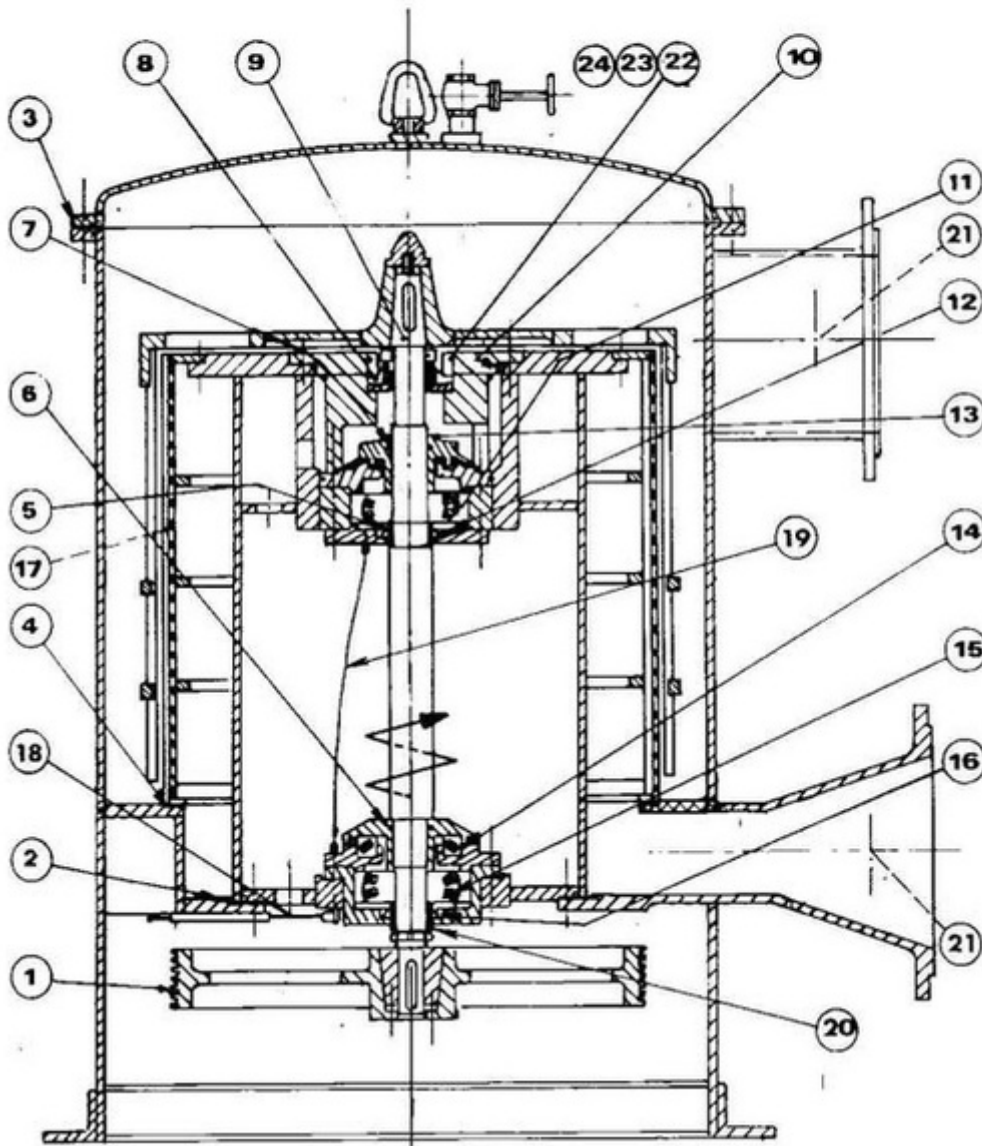

SPN	3	4	6	- 3 - 7	8	10	12	15	17	2
Total weight(kg)		700	1050	1600	1930	3500	4900	8500	13000	
Occupied floor space (m ²)		1,120	1,50	2	3,30	4,6	5,40	5,60	9,5	
All out height (m)		1,210	1,650	1,850	2,085	2,685	3,00	3,450	4,190	
Ø Piping inlet/outlet (mm)		150	250	300	350	400	500	600	800	
Ø Piping rejects (mm)		65	80	80	100	125	150	200	200	
Ø Piping desaeration (gas)		1"	1"	1"	1"	2"	2"	2"	2"	
Agitator speed (RPM)		543	370	330	247	242	182,5	137	137	
Inst. power (kW)		7,5	15	18,5	22	37	45	55	75	
Height under lifiting hook (m)		1,870	2,440	2,900	3,16	4,05	4,535	5,500	6,700	

Connection pipes must be of rigid construction with the exception of the desaeration piping.

When installing a pressure screen, the arrangement of discharge ports at the lowest points of the piping must not be omitted.

3. TREATMENT OF REJECTS

Generally, the proportion of rejects is as follows :

- 5 to 10 % of the production, according to the nature of stock.

To these rejects must be added the small outflow from the air bleed opening at the top of the unit (1 %) which must be permanently visible.